

WRLB-Serisi Milsiz Silindirler / WRLB Series Rodless Cylinders

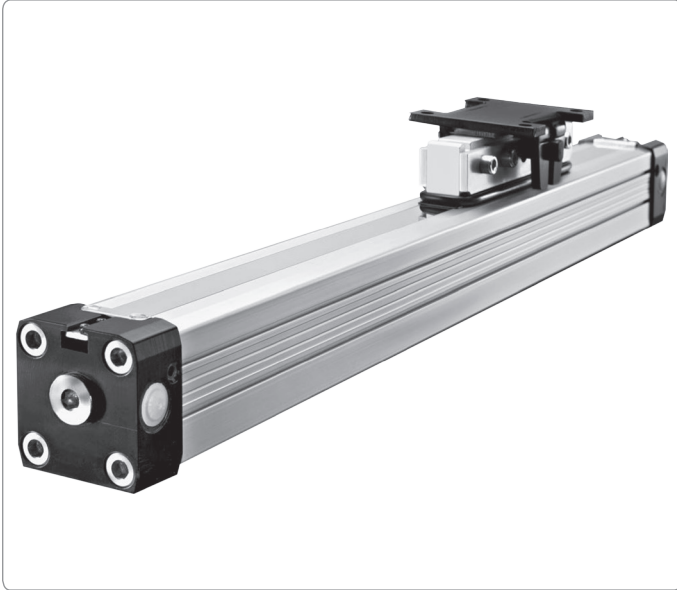

The entire tube is slotted throughout its full length. The force is transmitted through the load friction, which is attached to the piston axle.

The design of the piston axle is that way that the inner part of the piston axle is connected through the slot with the outer part of it. Therefore the force transmission runs as follows:

Air pressure > Piston area > piston axle (inner part) > piston axle (outer part) > load friction > load.

The sealing of the cylinder slot is guaranteed by a most precisely grinded inner steel band. The inner band is kept in position due to magnet stripes which are placed on both sides of the slot. In addition there is an outer steel band covering the slot in order to keep dust out of inner space of the cylinder.

During piston movement as well as during stillstand of it both steelbands are lifted right after the piston seal and led through the piston axle by means of a separate own guiding channel. Before and behind the piston axle both bands are covering the slot permanently again.

Technical Data

Design	Rodless cylinder, double acting, direct force transmission
Strokes	
ø 25-40 mm	100-5700mm, in increments of 1mm (longer strokes on request)
ø 16 mm	100-4400mm, in increments of 1mm
Air connection	(M5, G 1/8", G 1/4", g3/8")
Mounting	free
Forces + moments	see Forces and moments
Support Forces	see Deflection Diagram
Temperatures	(-10°C bis +80°C) other temperatures on request
Materials	
Barrel	High-strength anodized aluminum
End caps	High-strength anodized aluminum
Piston axle	High-strength anodized aluminum
Seals	Oilproof synthetic material (V < 1m/s (NBR)(V > 1m/s (VITON)
Sealing bands	Stainless steel
Piston caps	Wear proof synthetic material
Sliding parts	Wear proof synthetic material
Pressure range	0,5-8,0 bar
Medium	compressed air, filtered max. 50 µm

Benefits

- Equal forces on both ends of the piston
- Force connection direct, torque safe
- Piston with or without magnets
- 50% space-savings
- Long strokes up to 5700mm
- End caps with 3 air connections and adjustable cushioning
- Fast acceleration and high piston velocity
- Very flexible in the user`s design
- Non lubricated or lubricated air supply**)
- 3 stage cushioning characteristics for protection of the cushioning-and loadsystem*)
- Use in EX area possible - ATEX
 - *) Special Version On request
 - ***) Attention: Before changing operation from lubricated to nonlubricated air the cylinder has to be disassembled, cleaned, newly greased and reassembled

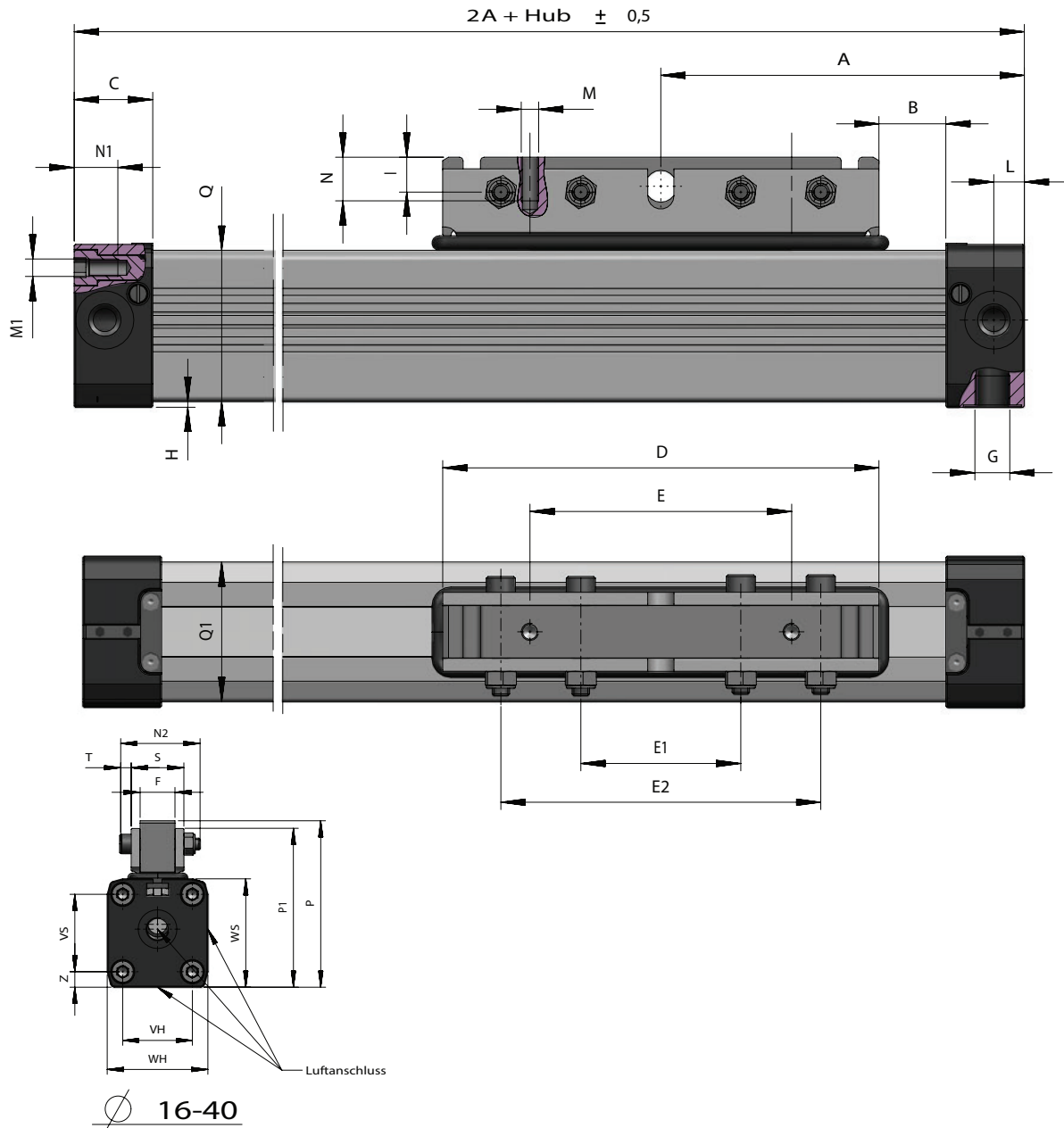

Dimensions

Ø	A	B	C	D	E	E1	F	G	I	L	M	M1	N1	N2	P-P1	P1	QXQ1	E2	H	S	T	VH	VS	WS	Z
16	65	12	15	76	48	32	10	M5	65	6	M4	M3	7	27	43,5 - 42,3	37,5	24,5X25	64	1,0	18	4	27	18	27	4,5
16L	90	37	15	76	48	32	10	M5	90	6	M4	M3	7	27	43,5 - 42,3	37,5	24,5X25	64	1,0	18	4	27	18	27	4,5
25	100	17	23	120	80	50	15	1/8"	100	13	M5	M5	10	35	66 - 58	53	36X36	100	2	23	5	40	27	40	6,5
25L	150	67	23	120	80	50	15	1/8"	150	13	M5	M5	10	35	66 - 58	53	36X36	100	2	23	5	40	27	40	6,5
32	125	23	27	150	90	55	18	1/4"	125	12	M6	M6	14	41	86 - 82	74	52X51	110	2	27	6	52	40	56	8
32L	200	23	27	300	180	120	18	1/4"	200	12	M6	M6	14	41	86 - 82	74	52X51	240	2	27	6	52	40	56	8
40	150	45	30	150	90	55	18	1/4"	150	12	M6	M6	17	41	97 - 93	85	58,5X59	110	7	28	6	72	54	69	9
40L	250	70	30	300	180	120	18	1/4"	250	12	M6	M6	17	41	97 - 93	85	58,5X59	240	7	28	6	72	54	69	9

- 16L – 40L : Cylinder with long piston for heavy bending and torque moments.
- P1:variable on request/details for standard Dimension is mentioned first.

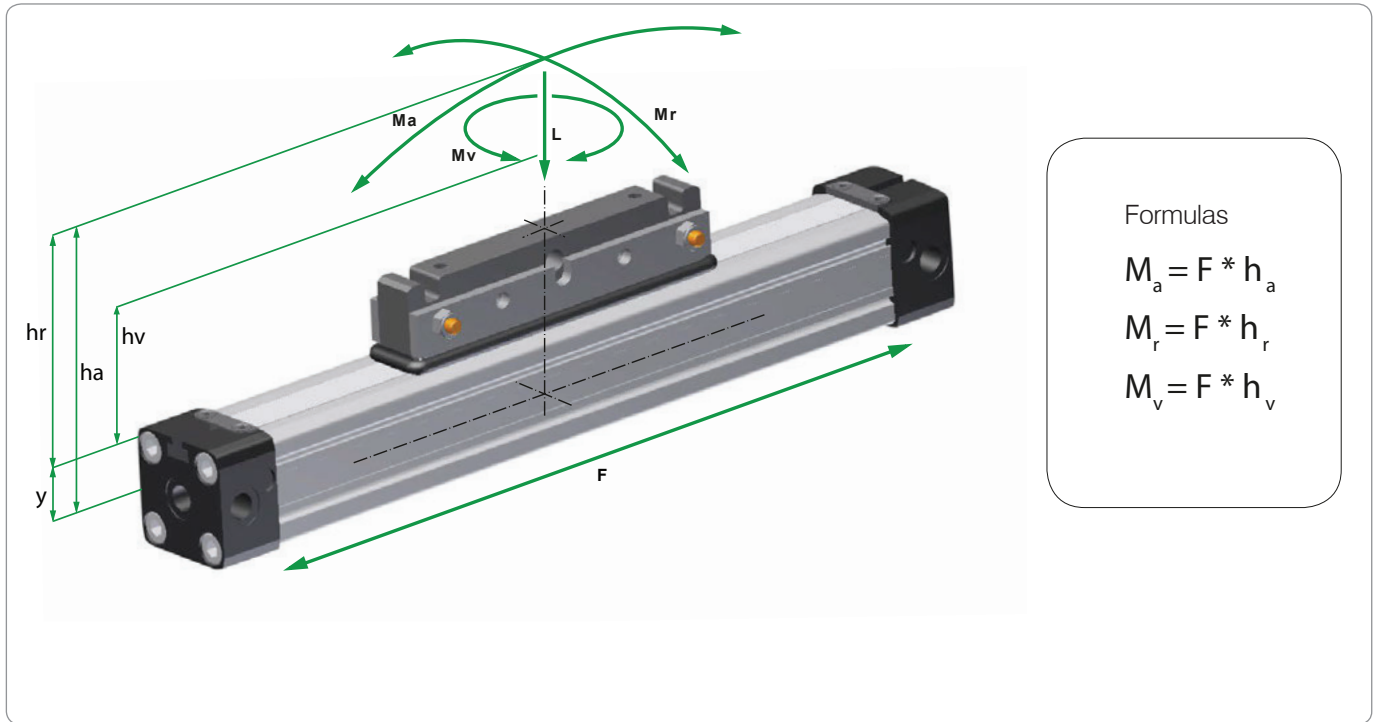

Forces and Moments

Cylinder		Effect Force (N)	Cushioning	Max. allowed load (N)		Max. allowed bending moments (Nm)		Max. allowed torque (Nm)
		at 6 Bar	(mm)	PL	PL			PL
Q	Y	F	S	L	Ma axial	Mr radial	Mv zentral	
16	9	110	15	120	4	0,3	0,3	
25	14	250	21	300	15	1,0	3,0	
32	18	420	26	450	30	2,0	4,5	
40	22	640	32	750	60	4,0	8,0	

The figures above are max. values based on light shock free duty and speed of $v \leq 0,2\text{m/sec}$ [PL-series] – $v \leq 0,45\text{m/sec}$ [PLF-series].

Max. pressure 6 bar.

An exceeding of the values in dynamic operations, even for short moments, has to be avoided.

Attention : Resulting forces could lead to extreme exceedings of the values. In case of undefinable situations the above max. values have to be underrun by 10-20%.

Please ask our sales representatives.

Cushioning Diagram

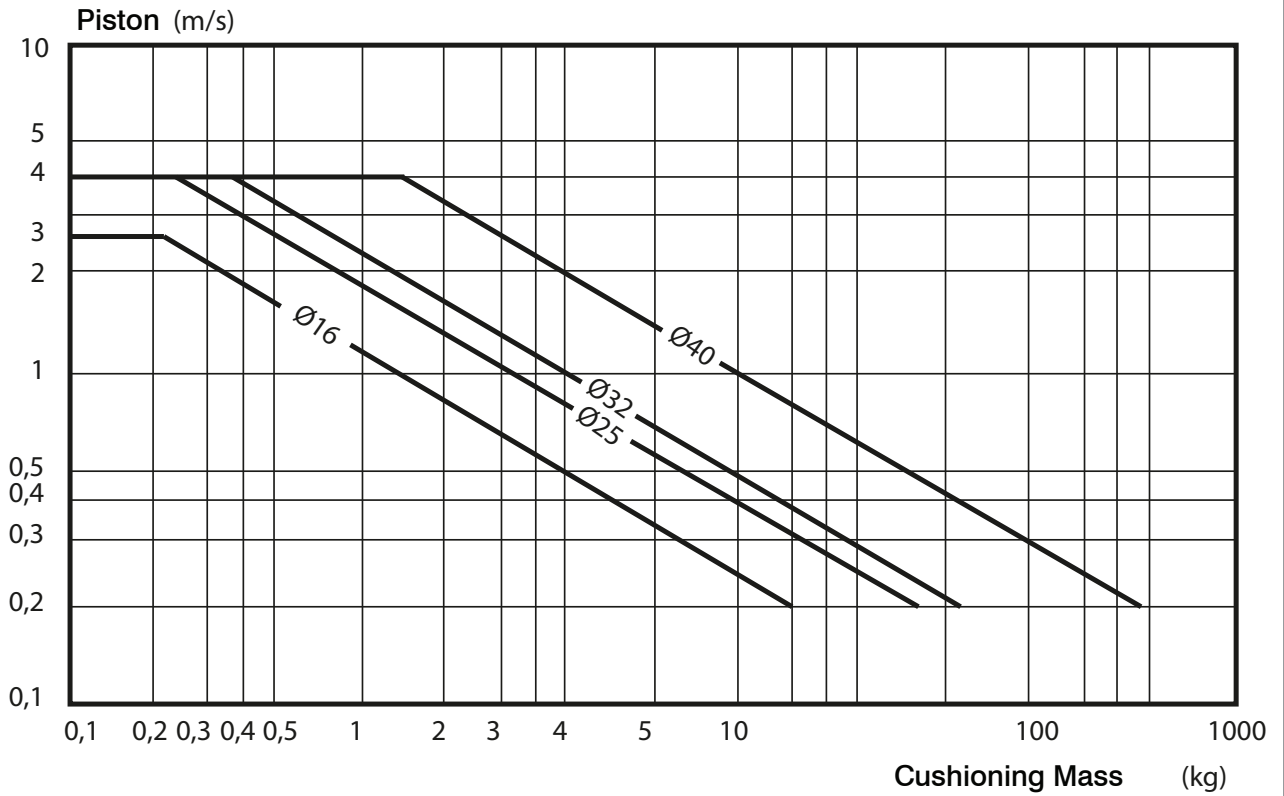

Pay attention to the following points:

- If the limits above are exceeded additional shock absorbers are necessary.
- For piston speeds of more than ≥ 1 m/s viton seals are recommended.
- For piston speeds $\leq 0,1$ m/s (NBR), $\leq 0,2$ m/s (VITON) slow speed lubrication is necessary see at sperpart kids
- Maximum duration life will be achieved when piston speeds do not exceed 1 m/s.

Deflection Diagram

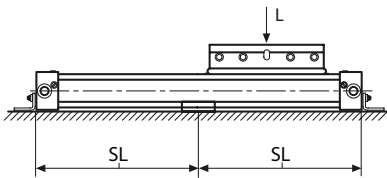
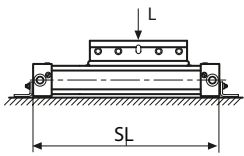
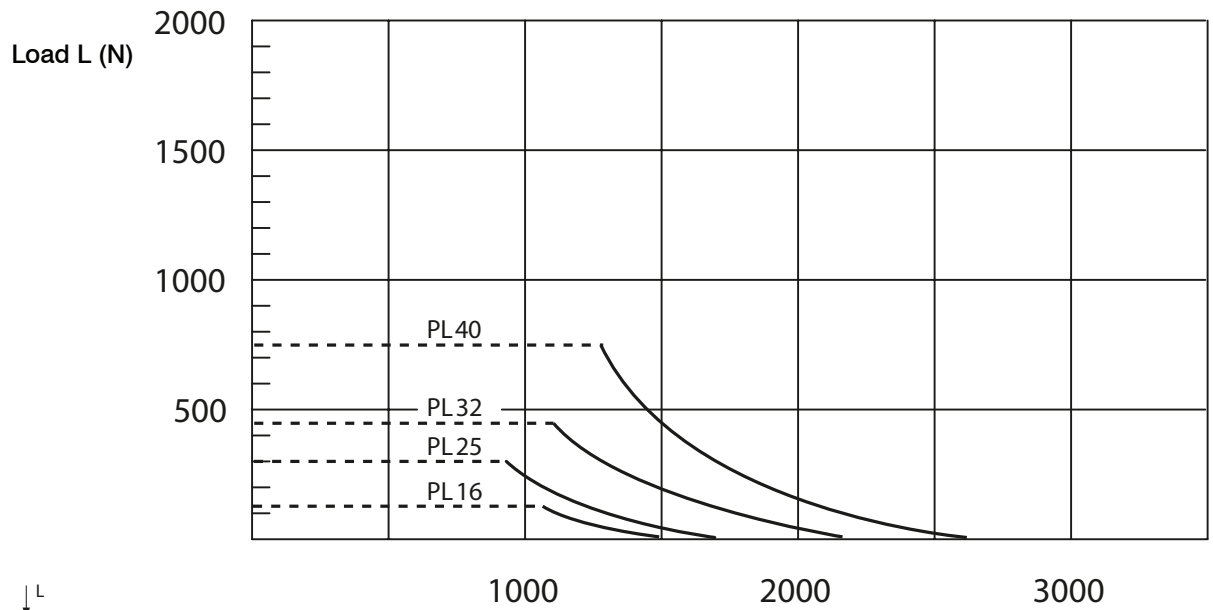

max. distance (SL) in mm - free of mounting No. 25

Deflection 1mm

Diagram Information:

- Calculated deflections without support of 0,5 – 1mm allow exceeding of supporting distance.
- Calculated deflections without support of 1mm – max 1,5mm require reduction of the supporting distance.